

HYUNDAI
POWER PRODUCTS

CONCRETE MIXER

HBTE650

ORIGINAL INSTRUCTIONS



GENUINE PRODUCT OF
HYUNDAI CORPORATION

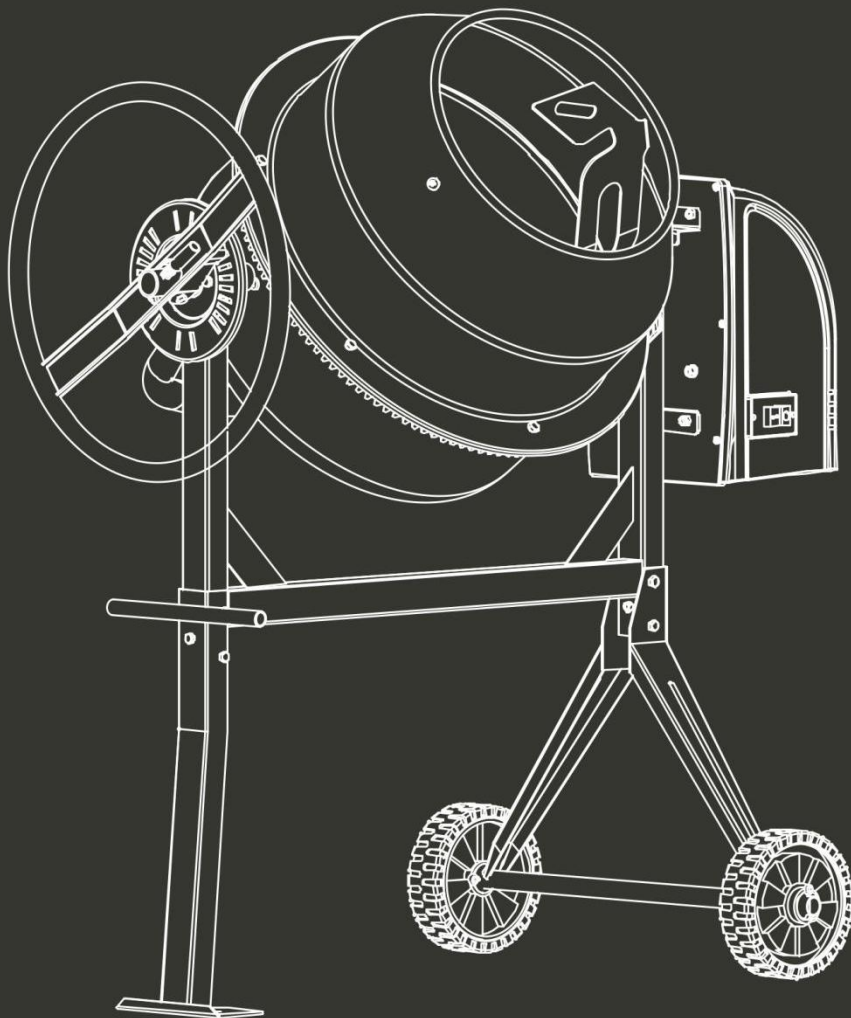

WARNING: Read thoroughly the instruction manual before using.

CONTENTS

1. INTENDED USE.....	3
2. RESIDUAL RISKS.....	3
3. SAFETY INSTRUCTIONS.....	3
4. ELECTRICAL SAFETY.....	5
5. SYMBOLS.....	7
6. PRODUCT DESCRIPTION.....	10
7. ASSEMBLY INSTRUCTIONS.....	11
8. OPERATION INSTRUCTIONS.....	16
9. MAINTENANCE AND STORAGE.....	18
10. TROUBLESHOOTING.....	20
11. DISPOSAL.....	20
12. DECLARATION OF CONFORMITY.....	21
13. WARRANTY.....	22
14. PRODUCT FAILURE.....	23
15. WARRANTY EXCLUSIONS.....	24



Read and understand the operating instructions before using the appliance. Familiarize with the control elements and how to use the appliance properly. Abide by all the safety measures stated in the service manual. In case of any doubts about connection and operation refer please to our customer center: <https://services.swap-europe.com/>

1. INTENDED USE

The concrete mixer has been designed to be used exclusively for concrete and mortar production. Do not use this product in any other way as stated for normal use. Not observing general regulations in force and instructions from this manual does not make the manufacturer liable for damages.

2. RESIDUAL RISKS

There can still be some residual risks given by the machine design despite using the machine in accordance with all the respective safety regulations. Residual risks may be minimized by following the safety instructions and use as designated provisions and the Operating Instructions. Caution reduces the risk of personal injury and material damage.



DANGER OF INJURY !

Risk of injury of fingers and hands when touching the running mixer drum by hand. Protection against dangerous getting caught or wound by the rotary spreader cannot be provided.



WARNING! Electric shock! There is a risk of an injury caused by electric shock!

Risk by current when using inappropriate connecting cables.

Do not touch supply conductors of exposed electrical components. There can still be some hidden risks despite all the preventive measures taken.

3. SAFETY INSTRUCTIONS

Please follow these instructions to protect yourself and other persons against potential risks and injuries.

1. Use protective equipment. Always wear safety glasses when working with the machine. The use of protective clothing is recommended, such as dust mask, protective gloves, eyes protection and sturdy non-slip footwear and ear defenders.

2. Do not touch, inhale (dust development) or consume the cement and additives.
3. Comply with the local injury prevention regulations and safety regulations in the work area.
4. Adequate light conditions must be provided.
5. The concrete mixer can only be used after complete installation of all parts.
6. Install and operate the concrete mixer on a solid and flat surface (making sure it does not fall over).
7. To prevent tripping, remove any obstacles on the site.
8. The operator is responsible to third persons in the work area.
9. Do not operate the mixer unattended.
10. Do not let children near the mixer.
11. Mixer to be only used for works given in paragraph "Use as designated".
12. Do not modify the machine or any of its parts.
13. The mixer can only be put into operation with complete and intact safety equipment.
14. Check the moving parts for perfect functioning, if working smoothly and if no parts are damaged. To provide safe operation of the equipment, all parts must be installed properly and meet all conditions.
15. Damaged protective equipment and parts must be professionally repaired or replaced by a recognized professional workshop, unless otherwise specified in the Operating Instructions.
16. Defective or damaged parts of the machine to be immediately replaced. Any damaged or illegible safety stickers must be replaced.
17. Original spare parts to be used only. Using other spare parts can result in accidents/injuries of the user. The manufacturer will not be liable for any such damage.
18. Check regularly this machine. Check all bolts, nuts, and screws for tightness before each use, especially those securing guards and drive mechanisms. Vibration during mixing may cause these to loosen.

19. Form a habit of checking to see that all the adjusting tools, shovels, hand towels and other tools/equipment are removed from mixer area before turning it on.
20. Replace damaged, missing or failed parts before using it. Warning labels carry important information. Replace any missing or damaged warning labels.
21. The tool shall be supervised when switched off and put out of children and animals, in order to avoid risks.
22. The machinery shall not be operating when it is being moved.
23. The mixer shall be positioned on level ground.
24. Do not reach into the drum interior to the rotating blades.
25. Warning - use only the original standard of insulation material for repair and to maintain insulation distances.
26. Disconnect the mixer from power supply before opening the enclosure and do not operate it unless the enclosure is fully closed.

4. ELECTRICAL SAFETY



Operation is only allowed with a safety switch against stray current (RCD max. current of 30mA).

WARNING! Before opening the housing, disconnect from the electric grid. The housing must be fully closed before operating the machine.

1. Concrete mixer with protective insulation, (Protection class II)
2. The machine can only be put into operation when the cladding is complete and firmly enclosed.
3. Before using the connecting cables, check them for defects or aging. Never use defective connecting cables.
4. Connecting cables not to be used for purposes for which they are not designed. Protect the cable against heat, oil and sharp edges. Do not use the connecting cable to pull the plug out of the socket.
5. Long and thin connecting cables cause a drop in voltage. The engine is no longer reaching its maximum power and the equipment function is reducing.
6. Cable must be unwound to the full extent when a cable drum is used.

7. When extending the connecting cable make sure it does not get jammed, broken and the plug is not wet.
8. Connecting cables with a rubber socket with a plug for more difficult conditions, protected against spraying water, to be used.
9. Do not use any provisional electric appliances. Never remove or switch off the protective equipment and never put it out of operation.
10. Design of the connecting cables according to IEC 60245-4 1980 (DIN 57 282) with H 07 RN-F marking or equivalent types of design. Core cross section of at least 3 x 1.5 mm² for a maximum length of 25 m.
11. Electrical connection and repairs on the electrical line must be provided by a licensed electrical professional and local regulations, the protective measures, in particular, must be complied with.
12. Repairs on electrical parts must be executed by the producer or companies specified by the producer.
13. If the supply cord is damaged, it must be replaced by a special cord or assembly available from the manufacturer or its service agent.

WARNING! The protection class II will only be maintained when original insulation materials/components

are used for a repair and when the insulation distances are not changed.

OPERATION

1. Never touch inside the running mixer drum. (rotary stirrer). Keep adequate safety distance from the mixer.
2. Prevent any contact with the rotary or moving parts of the machine.
3. The mixer drum to be only filled and emptied when the engine is running.
4. Pay attention to the mixer drum rotation direction.
5. Do not change the engine revolutions as they regulate the maximum safe work speed possible and protect the engine and all rotating parts against damage by excessive speed.
6. Check the mixer for stability.
7. The full mixer drum is heavy - BE CAREFUL when emptying the drum.

8. The mixer must necessarily be unplugged before:

- (1) Relocation and transport
- (2) Cleaning, servicing and repair
- (3) Failure removal
- (4) Check the connecting cables if not knotty or damaged
- (5) Leaving (even in case of short interruption)

STORAGE

Keep any equipment not being used in dry and locked spaces.

TRANSPORT



Move the concrete mixer with trailer.

WORK INSTRUCTIONS









Mixture production:

- 1. Add water and a couple of additive shovels (sand, gravel, etc.)
- 2. Add a couple of binder shovels (cement, lime, etc.)
- 3. Repeat points 1 and 2 until the required mixture ratio is achieved.
- 4. Let the mixture mix up properly.
- 5. Ask for advice from a professional for the mixture composition and quality.

5. SYMBOLS

	<p>Caution!</p> <p>Read the operating instructions to reduce the risk of injury.</p>
	<p>Always wear goggles when using the machine.</p>
	<p>Wear gloves!</p>

	<p>Wear safety shoes with steel reinforcement!</p>
	<p>Wear ear protectors!</p>
	<p>Always wear a breathing mask</p>
	<p>Always unplug the machine when not in use, before moving, making adjustments, changing parts, cleaning or working the machine.</p>
	<p>Keep distance of persons</p>
	<p>Do not touch inside the running mixer drum!</p>
	<p>(Rotary stirrer). Keep adequate safety distance from the mixer. Prevent any contact with the rotary or moving parts of the machine.</p>
	<p>Never attempt to move the machine when it is loaded and/or in use.</p>
	<p>Do not tow the machine with any vehicle.</p>
	<p>Take any residual materials to an authorized collection point or follow the regulations in the country where the machine is used. Do not discharge into drains, soil or water.</p>

	<p>Only use the machine on a solid, flat and level surface.</p>
	<p>Replace damaged, missing or failing parts before using the machine.</p>
	<p>Before switching on, always remove adjustment tools, shovels, hand trowels, and other tools from the machine area.</p>
	<p>Keep your hands away from all moving parts.</p>
	<p>Warning against dangerous voltage</p>
	<p>Sound power level L_{WA}</p>
	<p>CE marking</p>
	<p>Protection class II</p> <p>WARNING! This equipment is in safety class II. In order to maintain an adequate level of safety, only original insulating materials should be used and all clearance distances should be maintained.</p>
	<p>Any damaged or disposed electric or electronic devices must be delivered to appropriate collection centres.</p>

6. PRODUCT DESCRIPTION

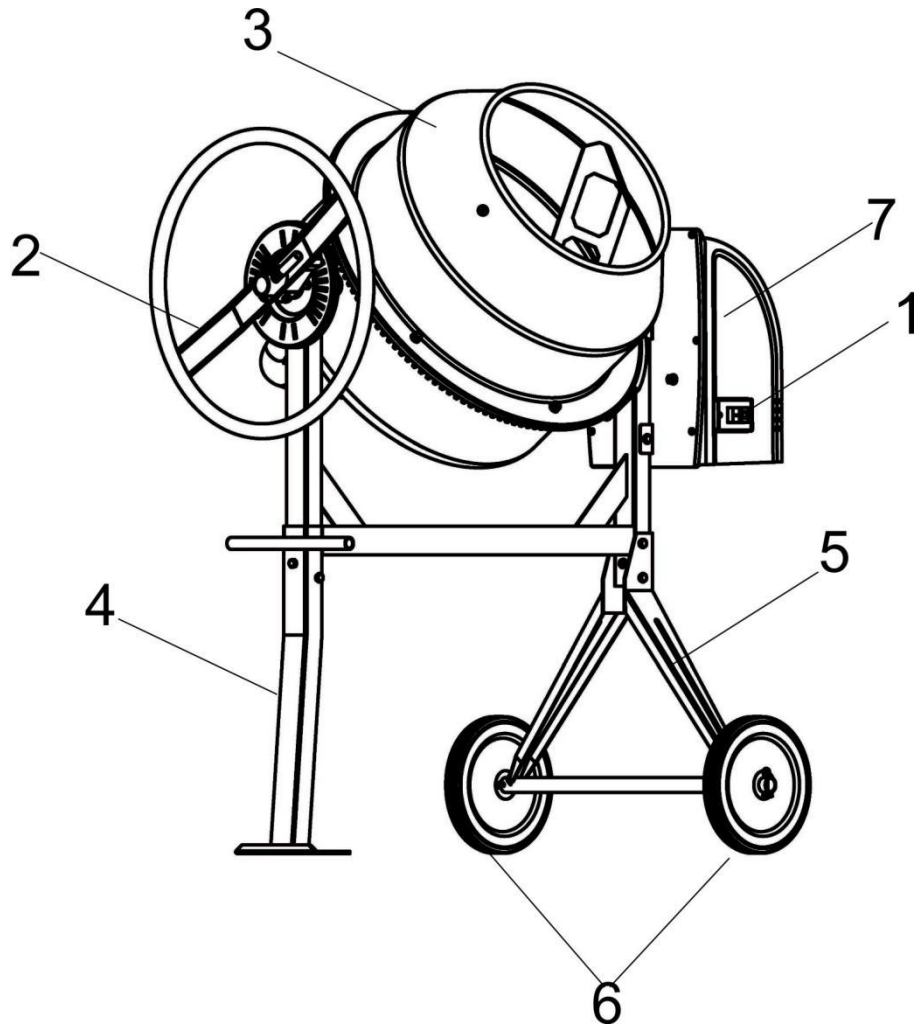

1. On/off switch
2. Operating wheel
3. Drum
4. Support bracket
5. Wheel bracket
6. Wheels
7. Motor compartment

TECHNICAL DATA

Mains voltage: 230V~, 50Hz

Power input: 650W (S6 30%)

Speed: 26.6/min

Drum capacity: 140L

Drum mouth size: 380mm

Weight: 52 kg

Degree of protection: IP44

Overall dimensions LxWxH in mm: 1200x710x1350mm

Sound pressure level L_{pA} (Distance 1 m, Height above the earth 1,55 m)
73.5dB(A)

Guaranteed sound power level L_{WA} : 95dB(A)

7. ASSEMBLY INSTRUCTIONS



Two people assist in assembly recommended.

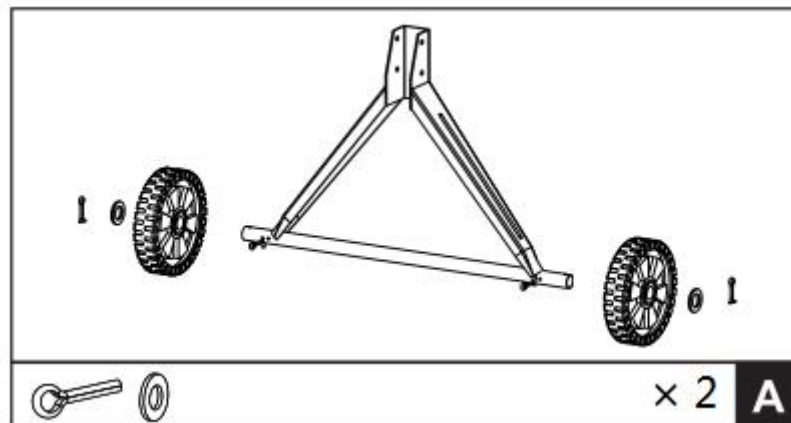

1. Slide the wheels over the stub axles. Secure with split pin retainers and flat washers.

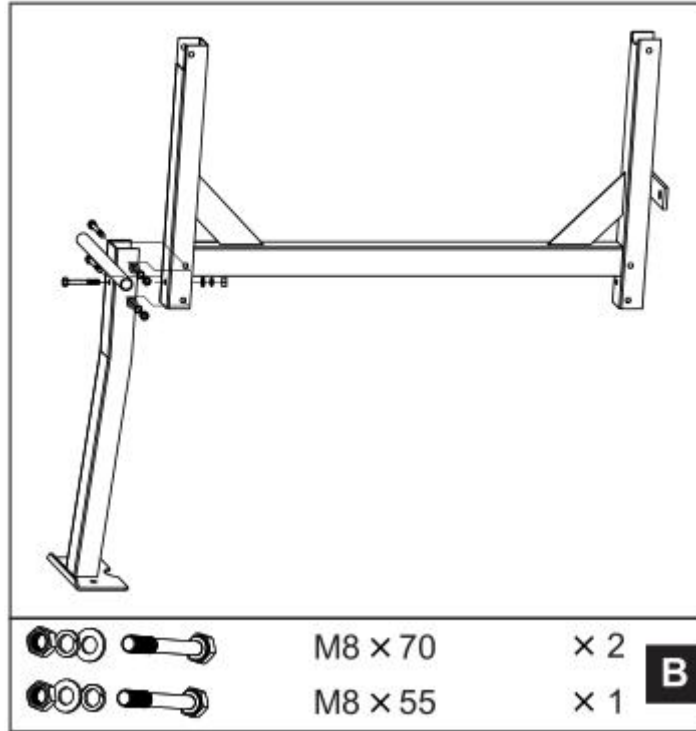

2. With the frame lying on its side, attach the support leg as shown. Insert two M8X70 hex bolts through the holes from one side, then flat washers, lock washers and nuts from the other side. Also screw a M8X55 hex bolt with lock and flat washers to the nut on the frame. Tighten down.

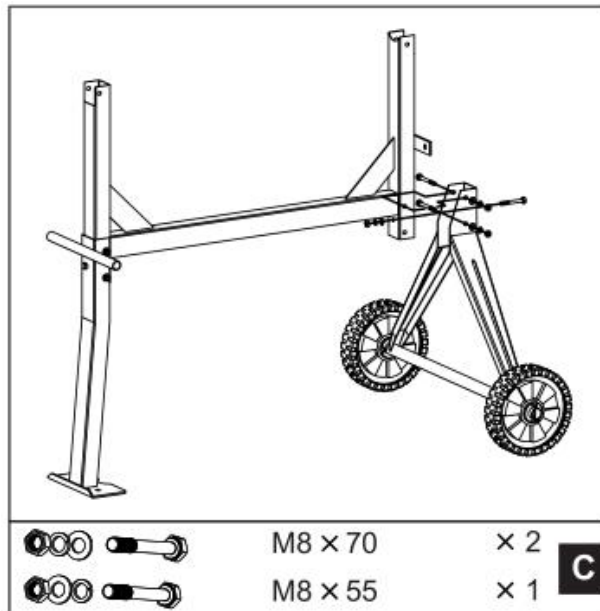

3. Turn the frame over and attach the axle bracket with wheels in the same manner.

4. Make sure all bolts and nuts are tightened.

THE BOTTOM DRUM

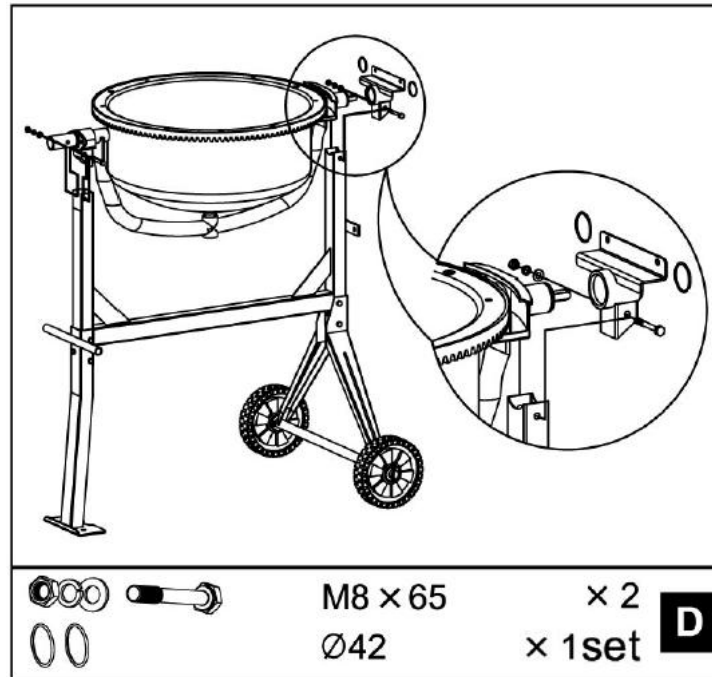

1. Slide the bearing block on the shaft. Hold it in place with the Ø42 spiral ring.
2. Carefully, and with two people, set the bottom drum with support arm onto the side supports of the stand as shown in the drawing. So that the bearing blocks slot into the channels provided by the side supports. The larger diameter shaft should be at the leg end of the stand.
3. At each side, line up the holes in the side support with those in the bearing block and insert a M8X65 hex bolt from one side, then a flat washer, lock washer and nut from the other side.
4. Tighten with a wrench.

THE MIXING BLADES

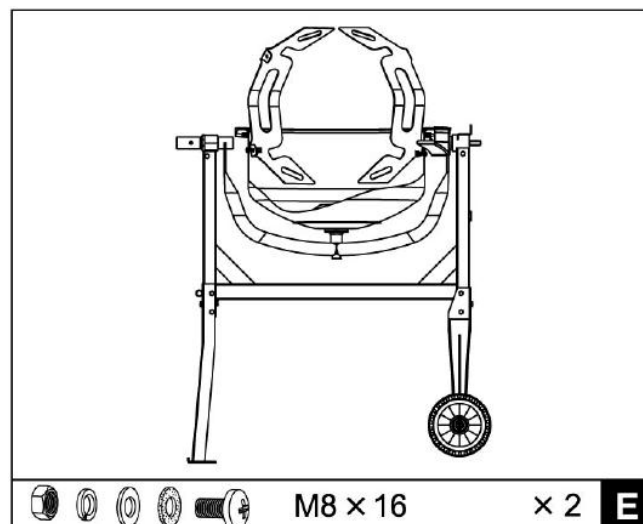

Mount the mixing blades inside the bottom drum loosely as shown - Two holes are provided at the base of the drum into which a M8X16 bolt may be inserted from the outside. A leather washer, flat washer, lock washer and a nut should be threaded on loosely on the inside.

The leather washer should be placed under the blade down against the drum.

NOTE: Two arrows are labeled on upper drum and bottom drum to make their position relation. If you have any difficulty in correctly positioning the mixing blades, it is helpful if you temporarily mount the upper drum on the top of the bottom drum, rotating it so that the two arrows line up.

THE UPPER DRUM

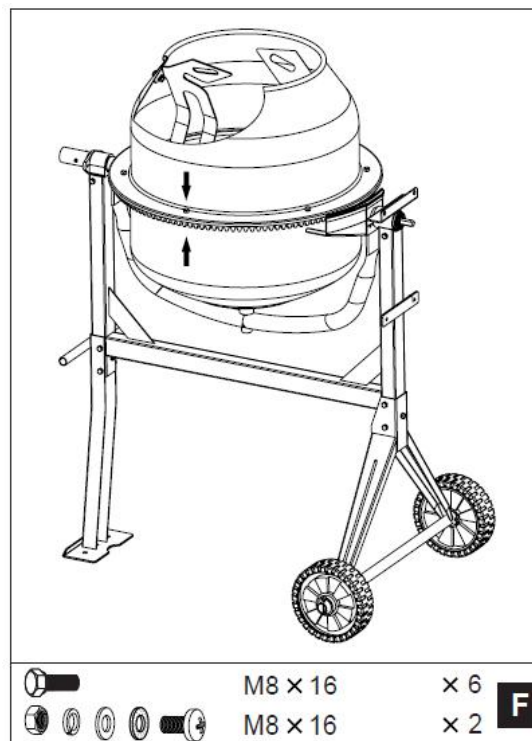

1. Position the upper drum on bottom drum over the rim, making sure the mounting holes align in both as well as the labeled arrows.
2. Screw a M8X16 hex bolt into each threaded hole in the rim/ring gear. Make sure the tightening process is carried out progressively.
3. Secure the mixing blades to the upper drum by inserting the two M8X16 cross headed screws, from the outside through the holes in the drum.
4. A washer should be positioned inside between the drum and blade. Secure the mixing blade on the inside using a flat washer, spring washer and nut.
5. Finally, ensure top and bottom mixing blade mountings are tight.

THE TIPPING WHEEL

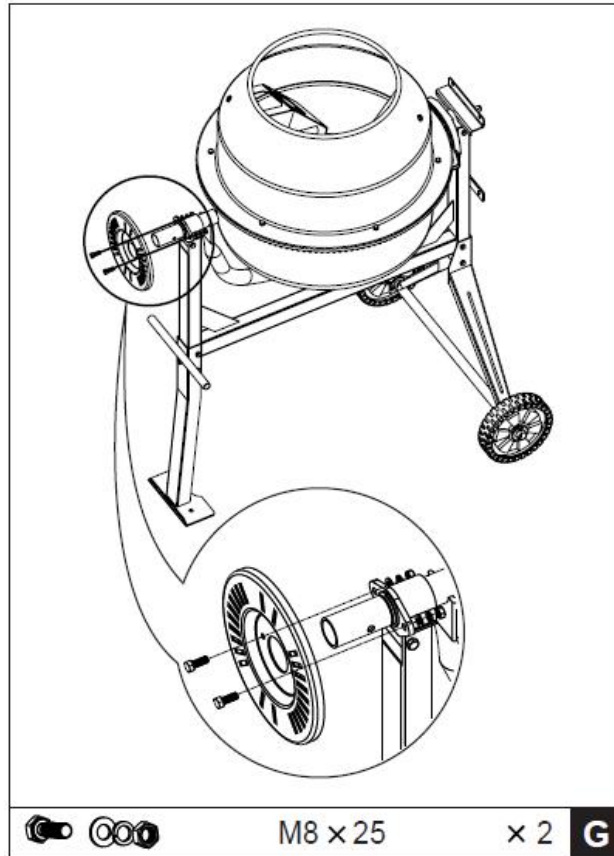

1. Slide the locking plate over the large diameter shaft at the leg end of the frame with the rim facing inwards as shown. Secure with two M8X25 bolts, each with a nut, lock and flat washers.

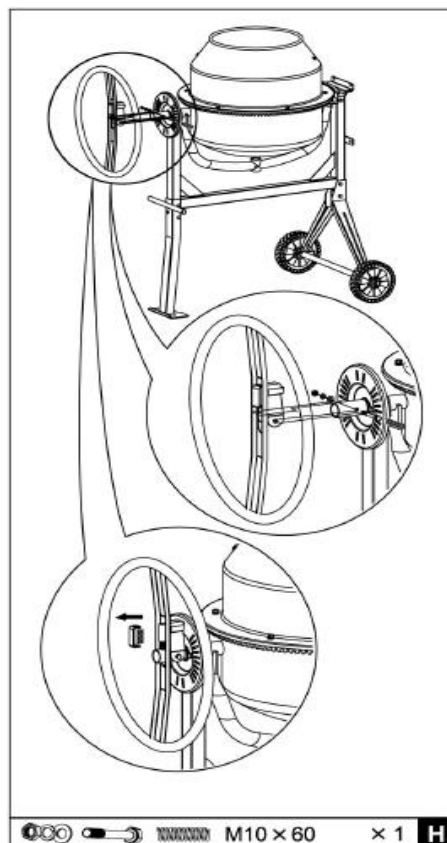

2. The spring is clamped in its holder by a U shaped plate for easier assembly. Slide the wheel over the larger diameter shaft until the holes in the bracket line up with the hole drilled. Insert a M10X60 hex bolt and screw on a nut with flat and lock washers from the other side. Screw the nut up against the bracket firmly, but not so tightly so as to prevent the wheel from pivoting about the bolt. Free the spring by removing the U shaped plate.

THE TRANSMISSION CASE

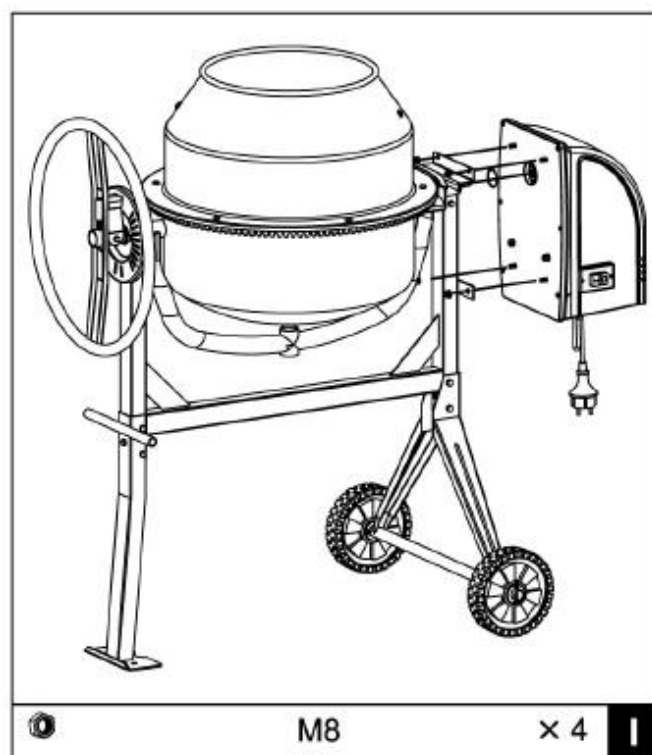

Lining up the keyways, slide the transmission case over the pinion shaft. Secure the case to the frame with four M8 nuts.

8. OPERATION INSTRUCTIONS

DRUM TILTING

The spring-loaded tipping wheel with locking lugs provides an easy positive control of the drum which can be locked in the mix, discharge and stored position.

The drum is locked in position by lugs on the self-locating tipping wheel which engage into the locking plate on the mixer frame. To tilt the drum, withdrawn the

tipping wheel to dis-engage the locking lugs. This then allows the tipping wheel and drum to be turned in the same direction.

To retain the drum in position, aligning the lugs with the slots, release the tipping wheel a little while retaining the drum. Rotate the tipping wheel until the locking lugs engage into the locking plate on the mixer frame..

Loading/Mixing Position

For Mortar

For Concrete

Emptying Position

Storage Position

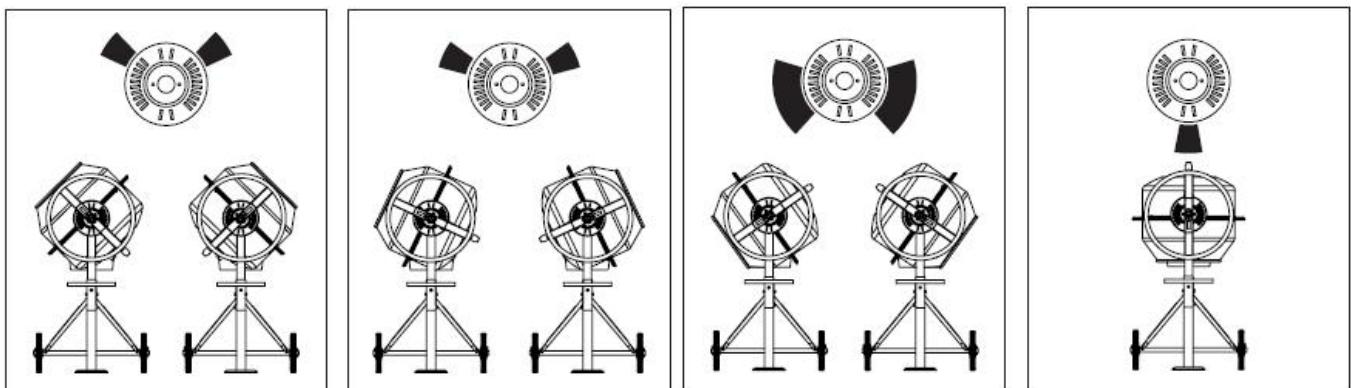

LOADING



Completely unwind the extension cord. Connect it to the concrete mixer first before plugging in power supply.



Always start the mixer before loading the drum. Loading the drum with drum rotating.



Do not throw material into the mixer to avoid sticking firmly to the back of the drum. Trickle it steadily over the ram.

NOTE: A built-in thermal protector is arranged in the motor to prevent it from overheating. The thermal protector restores automatically when the motor cools down.

For best results, proceed as follows:

1. Add the required amount of gravel into the drum.
2. Add the required amount of cement into the drum.
3. Add the required amount of sand into the drum.
4. Pour the required amount of water into the drum.

EMPTYING



Do not turn mixer off while full of load. Emptying the drum with drum rotating.

CLEANING



Never put hands inside the drum with drum rotating.

Thoroughly clean the mixer at the end of each day's operation. Keep your mixer clean. The slightest trace of material left in the drum will harden and attract more each time you use it until the machine is useless. Dried cement should be scraped out of the drum. Do not throw bricks into mixer drum to clean it out. Do not beat on the drum with a shovel, a hammer or other tools to break up accumulations of dried cement mix, as damage to the mixer may result. The drum may be scoured for approximate 2 minutes, using 1" gravel and water mixture. Then discharge the gravel/water mixture and hose down the drum assembly inside and out. The construction of protection class IP44 of the concrete mixer allows you to safely water the drum.



Do not pour or spray water directly over the motor cover, especially the openings in it.



Wipe off any external material on the motor cover. Do not use petrol, turpentine, lacquer or paint thinner, dry cleaning fluids or similar products. The use of chemical products or solvents may affect the properties of the cover which was made of high density polyethylene PET.

9. MAINTENANCE AND STORAGE



Ensure the extension cord is always unplugged before the motor cover is removed.

The drive belt is under constant even tension by a spring loaded jockey. No adjustment apart from a touch of grease on the spindle.

The bearings are sealed for life.



The wiring diagram and parts schematic in this manual are as reference tools only. Neither the manufacturer nor distributor makes any representation or warranty of any kind to the buyer that he or she is qualified to make any repairs to the product or that he or she is qualified to replace any parts of the product. Only qualified technicians should repair the mixer. Any maintenance and repairs carried out, to any of the electric components must be undertaken by a qualified electrician.



Parts in a circle should only be fitted by a qualified electrician.

WIRING DIAGRAM

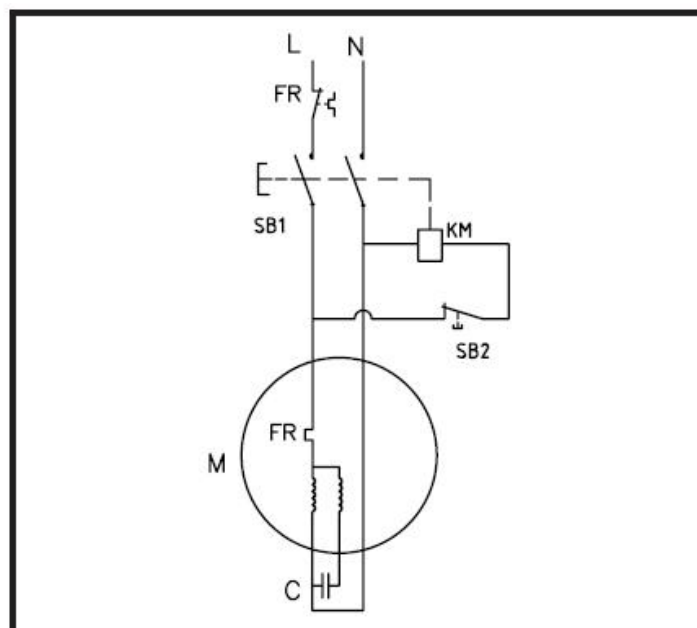

STORAGE

1. If the mixer is not in use, please unplug the power first and clean the external mud and dirt, as well as the granular feed and dirt inside the barrel. The machinery and equipment are proposed to be stored in a cool, dry, and well ventilated room.
2. The temperature of the room where the machine is stored should be between 0-40 °C, and attention should be paid to not being exposed to sunlight or rain to avoid oxidation and cracking of plastic parts and rusting and corrosion of iron parts, which may affect the service life of the machine.
3. Under normal circumstances, the machine needs to be powered on at regular intervals to prevent damage to the motor due to prolonged inactivity.

10. TROUBLESHOOTING

PROBLEM	PROBABLE CAUSE	REMEDY SUGGESTED
Can not start work	Not connect to power	Check if the power supply is connected
	Electromagnetic switch not closed or damaged	Check if the electromagnetic switch is engaged and damaged
	Excessive load or concentrate the load on one side	Reduce load Load equably
Shutdown during mixing	Excessive load	Reduce load
	Motor overheating	Stop Mixer and cooling the motor
Too much vibration	Bearing damage	Replacing bearings
	Unbalanced rotation	Verify balance
	Loose bolts in fastening parts	Tightening bolts
Current increased	Excessive load	Reduce load
	Rotating stuck	Inspect rotating components
Bearing temperature too high	Bearing damage	Replacing bearings
	Lack of oil in bearings	Supplementing oil

11. DISPOSAL



Electrical products should not be discarded with household products. According to the European Directive 2012/19/EU on waste electrical and electronic equipment and its implementation into national law, electrical products used must be collected separately and disposed of at collection points provided for this purpose. Talk with your local authorities or dealer for advice on recycling.

12. DECLARATION OF CONFORMITY



BUIDER SAS

ZI, 32 rue Aristide Bergès – 31270 Cugnaux – France

Declare that the following machine:

CONCRETE MIXER

HBTE650

Serial number : 20240604205-20240604492

Is in conformity with the Directive Machine 2006/42/EC and with the regulation transposing it.

Also in conformity with the following Directives:

EMC Directive 2014/30/EU

RoHS Directive 2011/65/EU & (EU) 2015/863

Also in conformity with the following standards

EN 12151:2007; EN ISO12100:2010

EN 60204-1:2018

EN 55014-1:2017/+A11:2020

EN 55014-2:2015

EN IEC61000-3-2:2019+A1:2021

EN 61000-3-3:2013+A1:2019

Responsible of the technical file: Mr Patriarca

Cugnaux, 08/04/2024

Philippe MARIE / PDG

13. WARRANTY

The manufacturer guarantees the product against defects in material and workmanship for a period of 2 years from the date of the original purchase. The warranty only applies if the product is for household use. The warranty does not cover breakdowns due to normal wear and tear.

The manufacturer agrees to replace parts identified as defective by the designated distributor. The manufacturer does not accept responsibility for the replacement of the machine, in whole or in part, and/or ensuing damage.

The warranty does not cover breakdowns due to:

- insufficient maintenance.
- abnormal assembly, adjustment or operations of the product.
- parts subject to normal wear and tear.

The warranty does not extend to:

- shipping and packaging costs.
- using the tool for a purpose other than that for which it was designed.
- the use and maintenance of the machine done in a manner not described in the user manual.

Due to our policy of continuous product improvement, we reserve the right to alter or change specifications without notice. Consequently, the product may be different from the information contained therein, but a modification will be undertaken without notice if it is recognized as an improvement of the preceding characteristic.

READ THE MANUAL CAREFULLY BEFORE USING THE MACHINE.

When ordering spare parts, please indicate the part number or code, you can find this in the spare parts list in this manual. Keep the purchase receipt; without it, the warranty is invalid. To help you with your product, we invite you to contact us by phone or via our website:

+33 (0)9.70.75.30.30

<https://services.swap-europe.com/contact>

You must create a "ticket" via the web platform.

- Register or create your account.
- Indicate the reference of the tool.
- Choose the subject of your request.
- Describe your problem.

Attach these files: invoice or sales receipt, photo of the identification plate (serial number), photo of the part you need (for example: pins on the transformer plug which are broken).



swap

14. PRODUCT FAILURE

WHAT TO DO IF MY MACHINE BREAKS DOWN?

If you bought your product in a store:

- Make sure that your machine is complete with all accessories supplied, and clean! If this is not the case, the repairer will refuse the machine.
- Go to the store with the complete machine and with the receipt or invoice.

If you bought your product on a website:

- Make sure that your machine is complete with all accessories supplied, and clean! If this is not the case, the repairer will refuse the machine.
- Create a SWAP-Europe service ticket on the site: <https://services.swap-europe.com> When making the request on SWAP-Europe, you must attach the invoice and the photo of the nameplate (serial number).

Contact the repair station to make sure it is available before dropping off the machine.

Go to the repair station with the complete machine packed, accompanied by the purchase invoice and the station support sheet downloadable after the service request is completed on the SWAP-Europe site

Please keep your original packaging to allow for after-sales service returns or pack your machine with a similar cardboard box of the same dimensions.

For any question concerning our after-sales service you can make a request on our website <https://services.swap-europe.com>

Our hotline remains available at +33 (9) 70 75 30 30.



15. WARRANTY EXCLUSIONS

THE WARRANTY DOES NOT COVER:

- Start-up and setting up of the product.
- Damage resulting from normal wear and tear of the product.
- Damage resulting from improper use of the product.
- Damage resulting from assembly or start-up not in accordance with the user manual.
- Breakdowns related to carburetion beyond 90 days and fouling of carburetors.
- Periodic and standard maintenance events.
- Actions of modification and dismantling that directly void the warranty.
- Products whose original authentication marking (brand, serial number) has been degraded, altered or withdrawn.
- Replacement of consumables.
- The use of non-original parts.
- Breakage of parts following impacts or projections.
- Accessories breakdowns.
- Defects and their consequences linked to any external cause.
- Loss of components and loss due to insufficient screwing.
- Cutting components and any damage related to the loosening of parts.
- Overload or overheating.
- Poor power supply quality: faulty voltage, voltage error, etc.
- Damages resulting from the deprivation of enjoyment of the product during the time necessary for repairs and more generally the costs related to the immobilization of the product.
- The costs of a second opinion established by a third party following an estimate by a SWAP-Europe repair station
- The use of a product which would show a defect or a breakage which was not the subject of an immediate report and/or repair with the services of SWAP-Europe.
- Deterioration linked to transport and storage*.
- Launchers beyond 90 days.
- Oil, petrol, grease.
- Damages related to the use of non-compliant fuels or lubricants.

* In accordance with transport legislation, damage related to transport must be declared to carriers within 48 hours maximum after observation by registered letter with acknowledgement of receipt. This document is a supplement to your notice, a non-exhaustive list.

Attention: all orders must be checked in the presence of the delivery person. In case of refusal by the delivery person, it you must simply refuse the delivery and notify your refusal.

Reminder: the reserves do not exclude the notification by registered letter with acknowledgement within 72 hours.

Information:

Thermal devices must be wintered each season (service available on the SWAP-Europe site). Batteries must be charged before being stored.

HYUNDAI
POWER PRODUCTS



GENUINE PRODUCT OF
HYUNDAI CORPORATION

For inquiries, please contact:

BUILDER SAS

32 rue Aristide Bergès - Z.I. du Casque - 31270 Cugnaux - France

Tél.: +33(0)5.34.502.502 Fax.: +33(0)5.34.502.503

<http://www.hyundaipower-fr.com/>

Fabriqué en République Populaire de Chine(PRC)

Importée par BUILDER SAS, France

Licensed by Hyundai Corporation Holdings, Korea